

Class IX Session 2023-24
Subject - Mathematics
Sample Question Paper - 9

Time Allowed: 3 hours

Maximum Marks: 80

General Instructions:

1. This Question Paper has 5 Sections A-E.
2. Section A has 20 MCQs carrying 1 mark each.
3. Section B has 5 questions carrying 02 marks each.
4. Section C has 6 questions carrying 03 marks each.
5. Section D has 4 questions carrying 05 marks each.
6. Section E has 3 case based integrated units of assessment (04 marks each) with subparts of the values of 1, 1 and 2 marks each respectively.
7. All Questions are compulsory. However, an internal choice in 2 Qs of 5 marks, 2 Qs of 3 marks and 2 Questions of 2 marks has been provided. An internal choice has been provided in the 2marks questions of Section E.
8. Draw neat figures wherever required. Take $\pi = 22/7$ wherever required if not stated.

Section A

1. The ordinate of every point on the x-axis is [1]
 - a) 1
 - b) any real number
 - c) 0
 - d) -1
2. The sides of a triangle are 325 m, 300 m and 125 m. Its area is [1]
 - a) 48750 m^2
 - b) 18750 m^2
 - c) 97500 m^2
 - d) 37500 m^2
3. In the given figure, O is the centre of the circle. If $\angle DBA = 35^\circ$, then the measure of $\angle ACB$ is equal to [1]

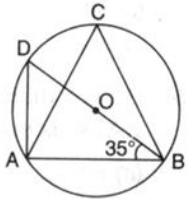

 - a) 65°
 - b) 55°
 - c) 45°
 - d) 60°
4. In the given figure, ABCD is a Rectangle. Find the values of x and y? [1]

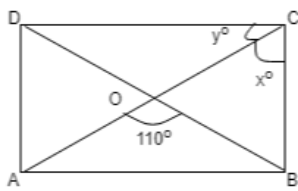

- a) $x = 120^\circ$ and $y = 120^\circ$
 c) $x = 55^\circ$ and $y = 35^\circ$

- b) $x = 50^\circ$ and $y = 60^\circ$
 d) $x = 60^\circ$ and $y = 70^\circ$

5. The value of $7^{\frac{1}{2}} \cdot 8^{\frac{1}{2}}$ is [1]

- a) $(28)^{1/2}$
 c) $(14)^{1/2}$

- b) $(56)^{1/2}$
 d) $(42)^{1/2}$

6. In the given figure, BO and CO are the bisectors of $\angle B$ and $\angle C$ respectively. If $\angle A = 50^\circ$ then $\angle BOC = ?$ [1]

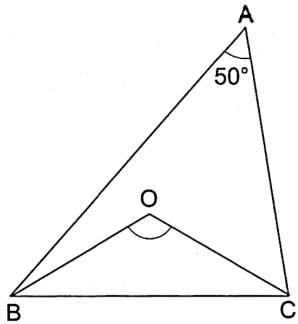

- a) 115°
 c) 100°

- b) 130°
 d) 120°

7. Which of the following is not a solution of $2x - 3y = 12$? [1]

- a) (0, -4)
 c) (6, 0)

- b) (2, 3)
 d) (3, -2)

8. If $x + \frac{1}{x} = 3$, then the value of $x^2 + \frac{1}{x^2}$ is [1]

- a) 0
 c) 1

- b) 7
 d) 9

9. The number of consecutive zeros in $2^3 \times 3^4 \times 5^4 \times 7$, is [1]

- a) 4
 c) 2

- b) 5
 d) 3

10. The diagonals AC and BD of a rectangle ABCD intersect each other at P. If $\angle ABD = 50^\circ$, then $\angle DPC =$ [1]

- a) 70°
 c) 90°

- b) 80°
 d) 100°

11. Choose the rational number which does not lie between $-\frac{2}{3}$ and $-\frac{1}{5}$ [1]

- a) $-\frac{7}{20}$
 c) $-\frac{1}{4}$

- b) $-\frac{3}{10}$
 d) $\frac{3}{10}$

12. The equation $x - 2 = 0$ on number line is represented by [1]

- a) infinitely many lines

- b) two lines

c) a point

d) a line

13. In the given figure, the value of x which makes POQ a straight line is:

[1]

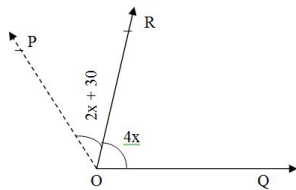

a) 40°

b) 30°

c) 35°

d) 25°

14. The value of $\frac{9\frac{1}{3} \times 27\frac{1}{2}}{3\frac{1}{6} \times 3\frac{1}{3}}$ is

[1]

a) 27

b) 9

c) 1

d) 3

15. In the given figure, O is the centre of a circle and $\angle ACB = 30^\circ$. Then, $\angle AOB = ?$

[1]

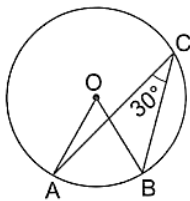

a) 90°

b) 60°

c) 30°

d) 15°

16. The point $(7, 0)$ lies

[1]

a) on the positive direction of y-axis

b) on the positive direction of x-axis

c) in quadrant IV

d) in quadrant II

17. The equation of x-axis is

[1]

a) $y = 0$

b) $x = 0$

c) $y = k$

d) $x = k$

18. The degree of the polynomial $(x^3 - 2)(x^2 - 11)$ is

[1]

a) 0

b) 5

c) 3

d) 2

19. **Assertion (A):** In $\triangle ABC$, median AD is produced to X such that $AD = DX$. Then $ABXC$ is a parallelogram.

[1]

Reason (R): Diagonals AX and BC bisect each other at right angles.

a) Both A and R are true and R is the correct explanation of A.

b) Both A and R are true but R is not the correct explanation of A.

c) A is true but R is false.

d) A is false but R is true.

20. **Assertion (A):** If $\sqrt{2} = 1.414$, $\sqrt{3} = 1.732$, then $\sqrt{5} = \sqrt{2} + \sqrt{3}$.

[1]

Reason (R): Square root of a positive real number always exists.

a) Both A and R are true and R is the correct explanation of A.

b) Both A and R are true but R is not the correct explanation of A.

c) A is true but R is false.

d) A is false but R is true.

Section B

21. In how many lines two distinct planes can intersect? [2]
22. In fig., if $AC = BD$, then prove that $AB = CD$ [2]

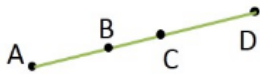

23. Name the quadrant in which the following points lie: (i) $A(2, 9)$ (ii) $B(-3, 5)$ (iii) $C(-4, -7)$ (iv) $D(3, -2)$ [2]
24. Find five rational numbers between $\frac{3}{5}$ and $\frac{2}{3}$ [2]

OR

Rationalise the denominator: $\frac{4}{2+\sqrt{3}+\sqrt{7}}$.

25. Find the volume and surface area of a sphere whose radius is 5m. [2]

OR

Find the volume of the largest right circular cone that can be cut out of a cube whose edge is 9 cm.

Section C

26. If $\sqrt{2} = 1.414$ and $\sqrt{3} = 1.732$, find the value of $\frac{5}{\sqrt{2}+\sqrt{3}}$ [3]
27. The following table gives the marks scored by 100 students in an entrance examination. [3]

Mark:	0-10	10-20	20-30	30-40	40-50	50-60	60-70	70-80
No. of Students (Frequency):	4	10	16	22	20	18	8	2

Represent this data in the form of a histogram.

28. In the following figure, triangle ABC is right angled at B. Given that $AB = 9$ cm., $AC = 15$ cm and D, E are the mid-points of AB and AC respectively. [3]

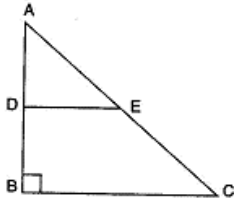

Calculate :

- i. The length of BC
ii. The area of $\triangle ADE$.
29. Find solutions of the form $x = a$, $y = 0$ and $x = 0$, $y = b$ for the following pairs of equations. Do they have any common such solution for equations $9x + 7y = 63$ and $x + y = 10$ [3]
30. Following table shows a frequency distribution for the speed of cars passing through at a particular spot on a high way: [3]

Class interval (km/h)	Frequency
30 - 40	3
40 - 50	6
50 - 60	25
60 - 70	65
70 - 80	50

80 - 90	28
90 - 100	14

Draw histogram and frequency polygon representing the data above.

OR

The following data on the number of girls (to the nearest ten) per thousand boys in different sections of Indian society is given below.

Section	Number of girls per thousand boys
Scheduled Caste (SC)	940
Scheduled Tribe (ST)	970
Non SC/ST	920
Backward districts	950
Non-backward districts	920
Rural	930
Urban	910

- Represent the information above by a bar graph.
- In the classroom discuss what conclusion can be arrived at from the graph.

31. Find the value of k , if $x - 1$ is a factor of $p(x)$ in case: $p(x) = kx^2 - \sqrt{2}x + 1$ [3]

Section D

32. In the given figure, $AB \parallel CD$. Prove that $p + q - r = 180$. [5]

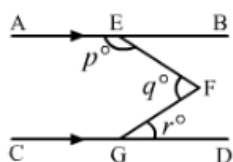

OR

Fig., $AB \parallel CD$ and $CD \parallel EF$. Also, $EA \perp AB$. If $\angle BEF = 55^\circ$, find the values of x , y and z .

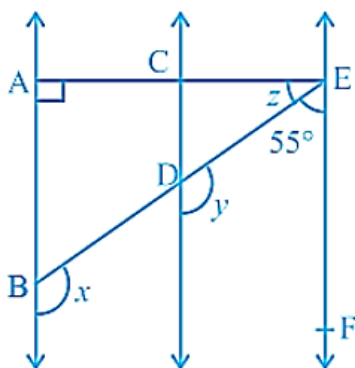

33. A tent is in the shape of a right circular cylinder up to a height of 3 m and conical above it. The total height of the tent is 13.5 m and the radius of its base is 14 m. Find the cost of cloth required to make the tent at the rate of Rs.80 per square metre. [Take $\pi = 22/7$] [5]

34. The perimeter of a right triangle is 144 cm and its hypotenuse measures 65 cm. Find the lengths of other sides and calculate its area. Verify the result using Heron's Formula. [5]

OR

The lengths of the sides of a triangle are 7 cm, 13 cm and 12 cm. Find the length of perpendicular from the opposite

vertex to the side whose length is 12 cm.

35. If $a + b + c = 5$ and $ab + bc + ca = 10$, then prove that $a^3 + b^3 + c^3 - 3abc = -25$ [5]

Section E

36. **Read the text carefully and answer the questions:** [4]

Reeta was studying in the class 9th C of St. Surya Public school, Mehrauli, New Delhi-110030

Once Ranjeet and his daughter Reeta were returning after attending teachers' parent meeting at Reeta's school.

As the home of Ranjeet was close to the school so they were coming by walking.

Reeta asked her father, "Daddy how old are you?"

Ranjeet said, "Sum of ages of both of us is 55 years, After 10 years my age will be double of you."



- (i) What is the second equation formed?
- (ii) What is the present age of Reeta in years?
- (iii) What is the present age of Ranjeet in years?

OR

If the ratio of age of Reeta and her mother is 3 : 7 then what is the age of Reeta's mother in years?

37. **Read the text carefully and answer the questions:** [4]

A children's park is in the shape of isosceles triangle said PQR with $PQ = PR$, S and T are points on QR such that $QT = RS$.

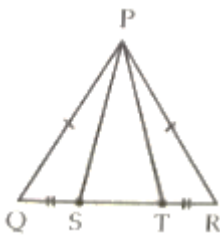

- (i) Which rule is applied to prove that congruency of $\triangle PQS$ and $\triangle PRT$.
- (ii) Name the type of $\triangle PST$.
- (iii) If $PQ = 6$ cm and $QR = 7$ cm, then find perimeter of $\triangle PQR$.

OR

If $\angle QPR = 80^\circ$ find $\angle PQR$?

38. **Read the text carefully and answer the questions:** [4]

There was a circular park in Defence colony at Delhi. For fencing purpose poles A, B, C and D were installed at the circumference of the park.

Ram tied wires From A to B, B to C and C to D, and he managed to measure the $\angle A = 100^\circ$ and $\angle D = 80^\circ$

Point O in the middle of the park is the center of the circle.

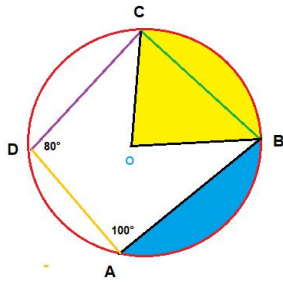

- (i) Name the quadrilateral ABCD.
- (ii) What is the value of $\angle C$?
- (iii) What is the value of $\angle B$.

OR

Write any three properties of cyclic quadrilateral?

Solution

Section A

1. (c) 0
Explanation: Every point on the x-axis is of the form $(a, 0)$. This means abscissa can be any real number but ordinate is always 0.

2. (b) 18750 m^2
Explanation: $a = 325 \text{ m}$, $b = 300 \text{ m}$, $c = 125 \text{ m}$
 $s = \frac{a+b+c}{2} = \frac{325+300+125}{2} = 375 \text{ m}$
 $s - a = 50 \text{ m}$, $s - b = 75 \text{ m}$, $s - c = 250 \text{ m}$
 $\text{Area} = \sqrt{s(s-a)(s-b)(s-c)}$
 $= \sqrt{375 \times 50 \times 75 \times 250}$
 $= \sqrt{15 \times 25 \times 25 \times 2 \times 3 \times 25 \times 25 \times 10}$
 $= \sqrt{25 \times 25 \times 25 \times 25 \times 30 \times 30}$
 $= 25 \times 25 \times 30$
 $= 18750 \text{ m}^2$

3. (b) 55°

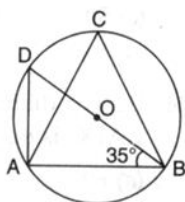

Explanation:

Join OA.

Now, in triangle AOB, from angle sum property we can find that $\angle AOB = 110^\circ$

Now, $2\angle ACB = \angle AOB = \frac{110^\circ}{2} = 55^\circ$

4. (c) $x = 55^\circ$ and $y = 35^\circ$
Explanation: Given $\angle AOB = 110^\circ$
 $\Rightarrow \angle DOC = 110^\circ$ vertically opposite angles
 $\triangle DOC$ we have:
 $DO = OC$
Now, $\angle ODC = \angle OCD = y$
now in $\triangle ODC$
 $y + y + 110^\circ = 180^\circ$ (angle sum property of triangle)
 $\Rightarrow 2y = 180^\circ - 110^\circ = 70^\circ$
 $\Rightarrow y = 35^\circ$
Also, $x = 90^\circ - y$
 $x = 90^\circ - 35^\circ = 55^\circ$
Hence, $x = 55^\circ$ and $y = 35^\circ$

5. (b) $(56)^{1/2}$

Explanation: $7^{\frac{1}{2}} \cdot 8^{\frac{1}{2}}$
 $= (7 \cdot 8)^{\frac{1}{2}}$
 $(56)^{1/2}$



6. (a) 115°

Explanation: In $\triangle ABC$ we have:

$$\angle A + \angle B + \angle C = 180^\circ \text{ [Sum of the angles of a triangle]}$$

$$\Rightarrow 50^\circ + \angle B + \angle C = 180^\circ$$

$$\Rightarrow \angle B + \angle C = 130^\circ$$

$$\Rightarrow \frac{1}{2}\angle B + \frac{1}{2}\angle C = 65^\circ \dots(i)$$

In $\triangle OBC$, we have :

$$\angle OBC + \angle OCB + \angle BOC = 180^\circ$$

$$\Rightarrow \frac{1}{2}\angle B + \frac{1}{2}\angle C + \angle BOC = 180^\circ \text{ [Using (i)]}$$

$$\Rightarrow 65^\circ + \angle BOC = 180^\circ$$

$$\Rightarrow \angle BOC = 115^\circ .$$

7.

(b) (2, 3)

Explanation: We have to check (2, 3) is a solution of $2x - 3y = 12$ if (2, 3) satisfy the equation then (2, 3) solution of $2x - 3y = 12$

$$\text{LHS} = 2x - 3y$$

$$2 \times 2 - 3 \times 3$$

$$4 - 9 = -5$$

$$\text{RHS} = -5$$

$$\text{LHS} \neq \text{RHS}$$

So (2, 3) is not a solution of $2x - 3y = 12$

8.

(b) 7

Explanation: $x + \frac{1}{x} = 3$

Squaring both sides, we get

$$x^2 + \frac{1}{x^2} + 2 \times x \times \frac{1}{x} = 9$$

$$\Rightarrow x^2 + \frac{1}{x^2} + 2 = 9$$

$$\Rightarrow x^2 + \frac{1}{x^2} = 7$$

9.

(d) 3

Explanation: The number of consecutive zeros in $2^3 \times 3^4 \times 5^4 \times 7$, is 3

As in the expression $2^3 \times 3^4 \times 5^4 \times 7$ has $2^3 \times 5^3$ which yields zeroes in expression.

As this would make 1000 i.e 3 zeroes will be there.

10.

(b) 80°

Explanation:

Given,

ABCD is a rectangle

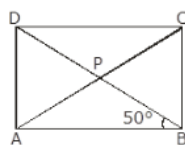

Diagonals AC & BD intersect each other at P

$$\angle ABD = 50^\circ$$

\therefore diagonals of rectangle bisect each other and are equal in length

$$\Rightarrow \angle ABD = \angle PDC \text{ [alternate angles]}$$

$$\Rightarrow \angle PDC = \angle PCD = 50^\circ$$

In $\triangle DPC$

$$\Rightarrow \angle DPC + \angle PCD + \angle PDC = 180^\circ$$

$$\Rightarrow \angle DPC + 50^\circ + 50^\circ = 180^\circ$$

$$\Rightarrow \angle DPC = 180^\circ - 100^\circ = 80^\circ$$

11.

(d) $\frac{3}{10}$

Explanation: Since $\frac{3}{10} > -\frac{2}{3}$ and $\frac{3}{10} > -\frac{1}{5}$

12.

(c) a point

Explanation: $x - 2 = 0$

$x = 2$ is a point on the number line

13.

(d) 25°

Explanation: We know that the measure of a straight angle is 180°

$$(2x + 30^\circ) + 4x = 180^\circ$$

$$2x + 30^\circ + 4x = 180^\circ$$

$$6x = 180^\circ - 30^\circ$$

$$6x = 150^\circ$$

$$x = \frac{150^\circ}{6} = 25^\circ$$

14.

(b) 9

Explanation: $\frac{9^{\frac{1}{3}} \times 27^{\frac{1}{2}}}{3^{\frac{-1}{6}} \times 3^{\frac{1}{3}}}$

$$\Rightarrow \frac{3^{\frac{2}{3}} \times 3^{\frac{3}{2}}}{3^{\frac{-1}{6}} \times 3^{\frac{1}{3}}}$$

$$\Rightarrow \frac{3^{\frac{2}{3} + \frac{3}{2}}}{3^{\frac{-1}{6} + \frac{1}{3}}}$$

$$\Rightarrow \frac{3^{\frac{4+9}{6}}}{3^{\frac{-1+2}{6}}}$$

$$\Rightarrow \frac{3^{\frac{13}{6}}}{3^{\frac{1}{6}}} = 3^{\frac{13}{6} - \frac{1}{6}}$$

$$\Rightarrow 3^{\frac{12}{6}} = 9$$

15.

(b) 60°

Explanation: We know that the angle at the centre of a circle is twice the angle at any point on the remaining part of the circumference. angles $\angle AOB$ and $\angle ACB$ are on the same arc AB.

Thus, $\angle AOB = (2 \times \angle ACB) = (2 \times 30^\circ) = 60^\circ$

16.

(b) on the positive direction of x-axis

Explanation: Since value of y-ordinate is zero so, point lies on x-axis.

But value of x is +ve so it lies on +ve direction of x-axis.

17. (a) $y = 0$

Explanation: Since x-axis is a parallel to itself at a distance 0 from it. Let P (x,y) be any point on the x-axis. Then clearly, for all position of P, we shall have the same ordinate 0 or, $y = 0$. Therefore, the equation of x-axis is $y = 0$.

18.

(b) 5

Explanation: $(x^3 - 2)(x^2 - 11)$

$$= x^3(x^2 - 11) - 2(x^2 - 11)$$

$$= x^5 - 11x^3 - 2x^2 + 22$$

Here the highest power is 5.

Therefore, the degree is 5.

19.

(c) A is true but R is false.

Explanation:

In quadrilateral ABXC, we have

AD = DX [Given]

BD = DC [Given]

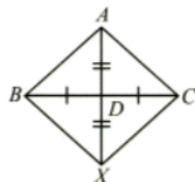

So, diagonals AX and BC bisect each other but not at right angles.

Therefore, ABXC is a parallelogram.

20.

(d) A is false but R is true.

Explanation: $\sqrt{2} + \sqrt{3} \neq 5$

$\sqrt{3} + \sqrt{2} = 1.732 + 1.414 = 3.146 \neq \sqrt{5}$ as $\sqrt{5} = 2.236$

Section B

21. One

It is this property which makes the plane "flat." Two distinct planes intersect in at most one point because only a single line is common to two intersecting planes.

22. $AC = BD \dots$ [Given] \dots (1)

$AC = AB + BC \dots$ [Point B lies between A and C] \dots (2)

$BD = BC + CD \dots$ [Point C lies between B and D] \dots (3)

Substituting (2) and (3) in (1), we get

$AB + BC = BC + CD$

$\Rightarrow AB = CD \dots$ [Subtracting equals from equals]

23. (i) I quadrant

(ii) II quadrant

(iii) III quadrant

(iv) IV quadrant

24. Since, $\frac{3}{5} < \frac{2}{3}$

Let $x = \frac{3}{5}$, $y = \frac{2}{3}$ and $n=5$

$$\therefore d = \frac{y-x}{n+1} = \frac{\frac{2}{3} - \frac{3}{5}}{5+1} = \frac{\frac{10-9}{15}}{6} = \frac{1}{90}$$

Thus, required rational numbers between $\frac{3}{5}$ and $\frac{2}{3}$ are

$x+d, x+2d, x+3d, x+4d$ and $x+5d$

i.e., $\frac{3}{5} + \frac{1}{90}, \frac{3}{5} + 2\left(\frac{1}{90}\right), \frac{3}{5} + 3\left(\frac{1}{90}\right), \frac{3}{5} + 4\left(\frac{1}{90}\right)$ and $\frac{3}{5} + 5\left(\frac{1}{90}\right)$

i.e., $\frac{54+1}{90}, \frac{3}{5} + \frac{1}{45}, \frac{3}{5} + \frac{1}{30}, \frac{3}{5} + \frac{2}{45}$ and $\frac{3}{5} + \frac{1}{18}$

i.e., $\frac{55}{90}, \frac{27+1}{45}, \frac{18+1}{30}, \frac{27+2}{45}$ and $\frac{54+5}{90}$

i.e., $\frac{11}{18}, \frac{28}{45}, \frac{19}{30}, \frac{29}{45}$ and $\frac{59}{90}$

OR

Number between $\frac{3}{5}$ and $\frac{2}{3}$

$$\frac{3}{5} = \frac{3 \times 3}{5 \times 3} = \frac{9}{15} = \frac{9 \times 6}{15 \times 6} = \frac{54}{90}$$

$$\frac{2}{3} = \frac{2 \times 3}{3 \times 3} = \frac{10}{15} = \frac{10 \times 6}{15 \times 6} = \frac{60}{90}$$

numbers are : $\frac{55}{90}, \frac{56}{90}, \frac{57}{90}, \frac{58}{90}, \frac{59}{90}$

OR

$$\begin{aligned} & \frac{4}{2+\sqrt{3}+\sqrt{7}} \\ &= \frac{4}{(2+\sqrt{3})+\sqrt{7}} \times \frac{(2+\sqrt{3})-\sqrt{7}}{(2+\sqrt{3})-\sqrt{7}} \\ &= \frac{4(2+\sqrt{3}-\sqrt{7})}{(2+\sqrt{3})^2-\sqrt{7}^2} \\ &= \frac{8+4\sqrt{3}-4\sqrt{7}}{4+4\sqrt{3}+3-7} \\ &= \frac{8+4\sqrt{3}-4\sqrt{7}}{4\sqrt{3}} \\ &= \frac{8+4\sqrt{3}-4\sqrt{7}}{4\sqrt{3}} \times \frac{\sqrt{3}}{\sqrt{3}} \\ &= \frac{8\sqrt{3}+12-4\sqrt{21}}{12} \\ &= \frac{2\sqrt{3}+3-\sqrt{21}}{3} \end{aligned}$$

25. Radius of sphere = 5m

$$\therefore \text{Volume of the sphere} = \left(\frac{4}{3}\pi r^3\right)$$

$$= \left(\frac{4}{3} \times \frac{22}{7} \times 5 \times 5 \times 5\right) \text{ m}^3$$

$$= 523.81 \text{ m}^3$$

$$\therefore \text{Surface area of the sphere} = (4\pi r^2)$$

$$= \left(4 \times \frac{22}{7} \times 5 \times 5\right) \text{ m}^2$$

$$= 314.28 \text{ m}^2$$

OR

The base of the largest right circular cone will be the circle inscribed in a face of the cube and its height will be equal to an edge of the cube.

$$\therefore r = \text{Radius of the base of the cone} = \frac{9}{2} \text{ cm, } h = \text{Height of cone} = 9 \text{ cm.}$$

$$\text{Hence, Volume of the cone} = \frac{1}{3}\pi r^2 h$$

$$\Rightarrow \text{Volume of the cone} = \frac{1}{3} \times \frac{22}{7} \times \frac{9}{2} \times \frac{9}{2} \times 9 = \frac{2673}{14} = 190.93 \text{ cm}^3$$

Section C

$$26. \frac{5}{\sqrt{2}+\sqrt{3}} \times \frac{\sqrt{2}-\sqrt{3}}{\sqrt{2}-\sqrt{3}} \text{ (Rationalizing denominator)}$$

$$\frac{5(\sqrt{2}-\sqrt{3})}{(\sqrt{2})^2-(\sqrt{3})^2} = \frac{5(\sqrt{2}-\sqrt{3})}{2-3}$$

$$= -5 [1.414 - 1.732]$$

$$= -5 \times -0.318 = 1.59$$

27. Taking class-intervals as bases and the corresponding frequencies as heights, we construct rectangles to obtain the histogram of the given frequency distribution as shown in Figure.

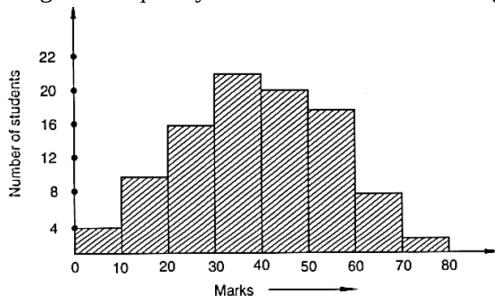

28. i. In right angled triangle ABC,

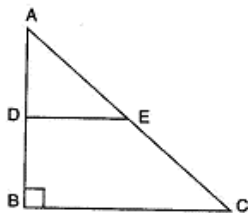

$$BC^2 = AC^2 - AB^2 \text{ (Using Pythagoras theorem)}$$

$$= (15)^2 - (9)^2 = 225 - 81$$

$$= 144$$

$$\Rightarrow BC = \sqrt{144} = 12 \text{ cm.}$$

ii. As D and E are the mid-points of AB and AC respectively.

$$\therefore DE \parallel BC \text{ and } DE = \frac{1}{2} BC = \frac{1}{2}(12) = 6 \text{ cm.}$$

$$AD = BD = \frac{1}{2} AB = \frac{1}{2}(9) = \frac{9}{2} \text{ cm.}$$

As $DE \parallel BC$ and AB intersects them

$$\therefore \angle ADE = \angle ABC = 90^\circ \dots [\text{Corresponding angles}]$$

$\Rightarrow \triangle ADE$ is a right-angled triangle.

$$\therefore \text{Area of } \triangle ADE = \frac{(AD)(DE)}{2} = \frac{9}{2} \cdot \frac{6}{2} = \frac{27}{2} = 13.5 \text{ cm}^2$$

29. $9x + 7y = 63$

put $x = 0$, we get

$$9(0) + 7y = 63$$

$$\Rightarrow 7y = 63$$

$$\Rightarrow y = \frac{63}{7} = 9$$

$\therefore (0, 9)$ is a solution.

$$9x + 7y = 63$$

Put $y = 0$, we get

$$9x + 7(0) = 63$$

$$\Rightarrow 9x = 63$$

$$\Rightarrow x = \frac{63}{9} = 7$$

$\therefore (7, 0)$ is a solution.

$$x + y = 10$$

Put $x = 0$, we get

$$0 + y = 10$$

$$\Rightarrow y = 10$$

$\therefore (0, 10)$ is a solution.

$$x + y = 10$$

Put $y = 0$, we get

$$x + 0 = 10$$

$$\Rightarrow x = 10$$

$\therefore (10, 0)$ is a solution.

The given equations do not have any common solution.

30. In the figure given below, a histogram and a frequency polygon (in dotted lines) are drawn on the same scale.

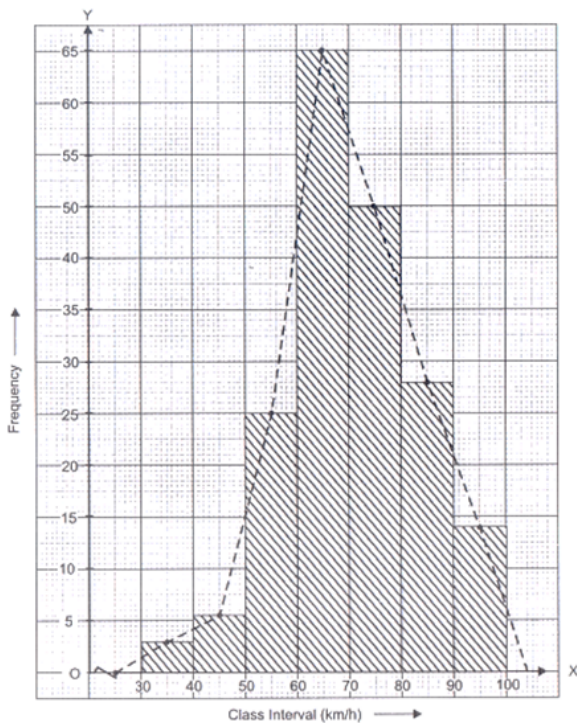

OR

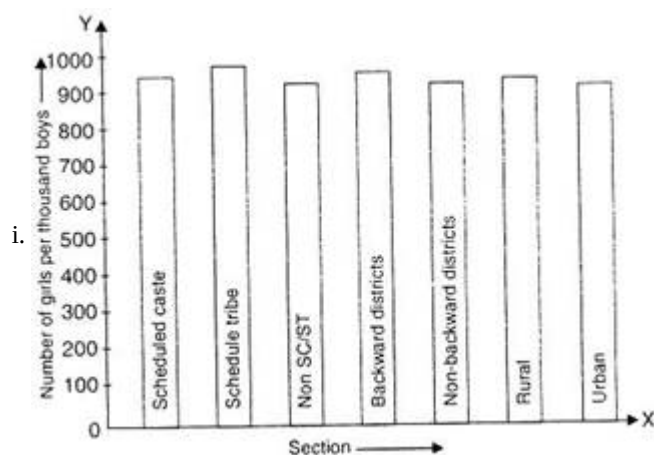

i. The two conclusions we can arrive at from the graph are as follows:

iii. The numbers of girls to the nearest ten per thousand boys is maximum in Scheduled Tribe section of the society and minimum in Urban section of the society.

iv. The number of girls to the nearest ten per thousand boys is the same for 'Non SC/ST' and 'Non-backward Districts' sections of the society.

31. $p(x) = kx^2 - \sqrt{2}x + 1$

We know that according to the factor theorem

$p(a) = 0$, if $x - a$ is a factor of $p(x)$

We conclude that if $(x - 1)$ is a factor of $p(x) = kx^2 - \sqrt{2}x + 1$, then $p(1) = 0$

$$p(1) = k(1)^2 - \sqrt{2}(1) + 1 = 0, \text{ or}$$

$$k - \sqrt{2} + 1 = 0$$

$$k = \sqrt{2} - 1.$$

Therefore, we can conclude that the value of k is $\sqrt{2} - 1$.

Section D

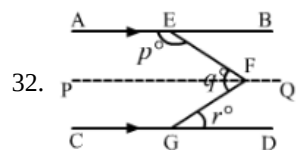

Draw $PFQ \parallel AB \parallel CD$

Now, $PFQ \parallel AB$ and EF is the transversal.

Then,

$$\angle AEF + \angle EFP = 180^\circ \dots(i)$$

[Angles on the same side of a transversal line are supplementary]

Also, $PFQ \parallel CD$.

$$\angle PFG = \angle FGD = r^\circ \text{ [Alternate Angles]}$$

$$\text{and } \angle EFP = \angle EFG - \angle PFG = q^\circ - r^\circ$$

putting the value of $\angle EFP$ in equation (i)

we get,

$$p^\circ + q^\circ - r^\circ = 180^\circ \text{ [}\angle AEF = p^\circ\text{]}$$

OR

Since corresponding angles are equal.

$$\therefore x = y \dots (i)$$

We know that the interior angles on the same side of the transversal are supplementary.

$$\therefore y + 55^\circ = 180^\circ$$

$$\Rightarrow y = 180^\circ - 55^\circ = 125^\circ$$

$$\text{So, } x = y = 125^\circ$$

Since $AB \parallel CD$ and $CD \parallel EF$.

$$\therefore AB \parallel EF$$

$$\Rightarrow \angle EAB + \angle FEA = 180^\circ \text{ [}\because \text{Interior angles on the same side of the transversal EA are supplementary]}$$

$$\Rightarrow 90^\circ + z + 55^\circ = 180^\circ$$

$$\Rightarrow z = 35^\circ$$

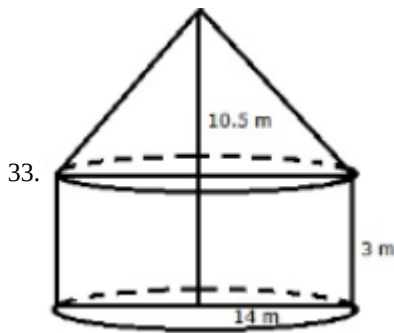

Radius of the cylinder = 14 m

And its height = 3 m

Radius of cone = 14 m

And its height = 10.5 m

Let l be the slant height

$$\therefore l^2 = (14)^2 + (10.5)^2$$

$$l^2 = (196 + 110.25)m^2$$

$$l^2 = 306.25 m^2$$

$$l = \sqrt{306.25}m$$

$$= 17.5 m$$

Curved surface area of tent

= (curved area of cylinder + curved surface area of cone)

$$= 2\pi rh + \pi rl$$

$$= \left[\left(2 \times \frac{22}{7} \times 14 \times 3 \right) + \left(\frac{22}{7} \times 14 \times 17.5 \right) \right] m^2$$

$$= (264 + 770)m^2 = 1034m^2$$

Hence, the curved surface area of the tent = $1034 m^2$

Cost of canvas = Rs.(1034×80)= Rs.82720

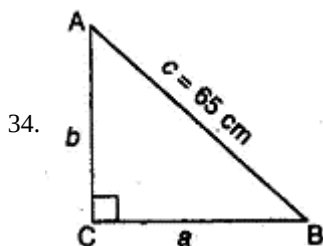

Let ABC be the right triangle angled at C.

Perimeter = 144 cm.

$$\Rightarrow a + b + c = 144 \dots (1)$$

$$\Rightarrow c = 65 \dots (2)$$

Subtracting (2) from (1)

$$a + b = 144 - 65$$

$$a + b = 79 \dots (3)$$

In right triangle ACB,

$$a^2 + b^2 = (65)^2 \dots [\text{By Pythagoras theorem}] \dots (4)$$

We know that

$$(a + b)^2 = a^2 + b^2 + 2ab$$

$$\Rightarrow (79)^2 = (65)^2 + 2ab \dots [\text{Using (3) and (4)}]$$

$$\Rightarrow 2ab = (79)^2 - (65)^2$$

$$\Rightarrow 2ab = (79 + 65)(79 - 65)$$

$$\Rightarrow 2ab = (144)(14)$$

$$\Rightarrow ab = (72)(14)$$

$$\Rightarrow ab = 1008$$

$$\begin{aligned} \text{Now, } (a - b)^2 &= (a + b)^2 - 4ab \dots (5) \\ &= (79)^2 - 4(1008) \dots [\text{From (3) and (5)}] \\ &= 6241 - 4032 = 2209 \\ a - b &= \sqrt{2209} \\ a - b &= 47 \dots (6) \end{aligned}$$

Solving (3) and (6)
 $a = 63, b = 16 \text{ cm.}$

$$\begin{aligned} \therefore \text{Area of the right triangle} \\ &= \frac{1}{2} \times \text{base} \times \text{height} \\ &= \frac{1}{2} \times 63 \times 16 = 504 \text{ cm}^2 \end{aligned}$$

Using Heron's Formula

$a = 63, b = 16 \text{ cm, } c = 65 \text{ cm.}$

$$\begin{aligned} \therefore s &= \frac{a+b+c}{2} \\ &= \frac{63+16+65}{2} = \frac{144}{2} = 72 \text{ cm.} \end{aligned}$$

$$\begin{aligned} \therefore \text{Area of the right triangle} &= \sqrt{s(s-a)(s-b)(s-c)} \\ &= \sqrt{72(72-63)(72-16)(72-65)} \\ &= \sqrt{72(9)(56)(7)} \\ &= \sqrt{(8 \times 9)(9)(8 \times 7)(7)} \\ &= 8 \times 9 \times 7 = 504 \text{ cm}^2 \end{aligned}$$

OR

Let, $a = 7 \text{ cm, } b = 13 \text{ cm, } c = 12 \text{ cm}$

$$\therefore s = \frac{a+b+c}{2} = \frac{7+13+12}{2} = \frac{32}{2} = 16 \text{ cm}$$

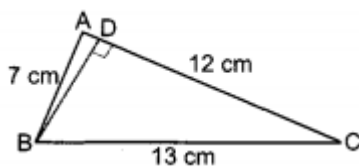

$$\begin{aligned} \text{Area of } \triangle ABC &= \sqrt{s(s-a)(s-b)(s-c)} \\ &= \sqrt{16(16-7)(16-13)(16-12)} \\ &= \sqrt{16 \times 9 \times 3 \times 4} = 24\sqrt{3} \text{ cm}^2 \end{aligned}$$

Also, Area of $\triangle ABC = \frac{1}{2} AC \cdot BD$

$$24\sqrt{3} = \frac{1}{2} \times 12 \times BD$$

$$\Rightarrow BD = \frac{24\sqrt{3} \times 2}{12} = 4\sqrt{3} \text{ cm}$$

Hence, the length of perpendicular from the opposite vertex to the given side is $4\sqrt{3} \text{ cm.}$

35. As we know,

$$\begin{aligned} a^3 + b^3 + c^3 - 3abc &= (a + b + c)(a^2 + b^2 + c^2 - ab - bc - ca) \\ &= (a + b + c)[a^2 + b^2 + c^2 - (ab + bc + ca)] \\ &= 5\{a^2 + b^2 + c^2 - (ab + bc + ca)\} \\ &= 5(a^2 + b^2 + c^2 - 10) \end{aligned}$$

Now, $a + b + c = 5$

Squaring both sides, we get

$$(a + b + c)^2 = 5^2$$

$$\Rightarrow a^2 + b^2 + c^2 + 2(ab + bc + ca) = 25$$

$$\therefore a^2 + b^2 + c^2 + 2(10) = 25$$

$$\Rightarrow a^2 + b^2 + c^2 = 25 - 20 = 5$$

$$\text{Now, } a^3 + b^3 + c^3 - 3abc = 5(a^2 + b^2 + c^2 - 10)$$

$$= 5(5 - 10) = 5(-5) = -25$$

Hence, proved.

Section E

36. Read the text carefully and answer the questions:

Reeta was studying in the class 9th C of St. Surya Public school, Mehrauli, New Delhi-110030

Once Ranjeet and his daughter Reeta were returning after attending teachers' parent meeting at Reeta's school. As the home of

Ranjeet was close to the school so they were coming by walking.

Reeta asked her father, "Daddy how old are you?"

Ranjeet said, "Sum of ages of both of us is 55 years, After 10 years my age will be double of you."



(i) $x - 2y = 10$

(ii) $x + y = 55$... (i) and $x - 2y = 10$... (ii)

Subtracting (ii) from (i)

$$x + y - x + 2y = 55 - 10$$

$$\Rightarrow 3y = 45$$

$$\Rightarrow y = 15$$

So present age of Reeta is 15 years.

(iii) $x + y = 55$... (i) and $x - 2y = 10$... (ii)

Subtracting (ii) from (i)

$$x + y - x + 2y = 55 - 10$$

$$\Rightarrow 3y = 45$$

$$\Rightarrow y = 15$$

Put $y = 15$ in equation (i)

$$x + y = 55$$

$$\Rightarrow x + 15 = 55$$

$$\Rightarrow x = 55 - 15 = 40$$

So Ranjeet's present age is 40 years.

OR

Let Reeta's mother age be 'z'.

Given Reeta age : Her mother age = 7 : 5

We know that Reeta age = 15 years

$$\frac{\text{Mother age}}{\text{Reeta age}} = \frac{7}{5}$$

$$\Rightarrow z = \frac{7}{5} \times y$$

$$\Rightarrow z = \frac{7}{5} \times 15$$

\Rightarrow Here Mother age = 35 years

Hence Reeta's mother's age is 35 years.

37. Read the text carefully and answer the questions:

A children's park is in the shape of isosceles triangle said PQR with $PQ = PR$, S and T are points on QR such that $QS = TR$.

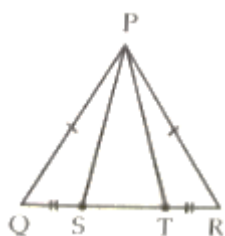

(i) In $\triangle PQS$ and $\triangle PRT$

$PQ = PR$ (Given)

$QS = TR$ (Given)

$\angle PQR = \angle PRQ$ (corresponding angles of an isosceles \triangle)

By SAS commence

$\triangle PQS \cong \triangle PRT$



$$(ii) \triangle PQS \cong \triangle PRT$$

$$\Rightarrow PS = PT \text{ (CPCT)}$$

So in $\triangle PST$

$$PS = PT$$

It is an isosceles triangle.

(iii) Perimeter = sum of all 3 sides

$$PQ = PR = 6 \text{ cm}$$

$$QR = 7 \text{ cm}$$

$$\text{So, } P = (6 + 6 + 7) \text{ cm}$$

$$= 19 \text{ cm}$$

OR

$$\text{Let } \angle Q = \angle R = x \text{ and } \angle P = 80^\circ$$

In $\triangle PQR$, $\angle P + \angle Q + \angle R = 180^\circ$ (Angle sum property of \triangle)

$$80^\circ + x + x = 180^\circ$$

$$2x = 180^\circ - 80$$

$$2x = 100^\circ$$

$$x = \frac{100^\circ}{2}$$

$$= 50^\circ$$

38. Read the text carefully and answer the questions:

There was a circular park in Defence colony at Delhi. For fencing purpose poles A, B, C and D were installed at the circumference of the park.

Ram tied wires From A to B, B to C and C to D, and he managed to measure the $\angle A = 100^\circ$ and $\angle D = 80^\circ$

Point O in the middle of the park is the center of the circle.

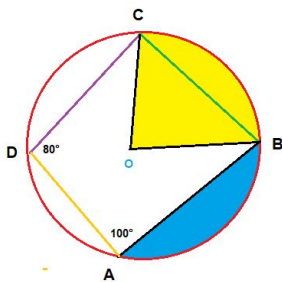

(i) ABCD is cyclic quadrilateral.

A quadrilateral ABCD is called cyclic if all the four vertices of it lie on a circle.

Here all four vertices A, B, C and D lie on a circle.

(ii) We know that the sum of both pair of opposite angles of a cyclic quadrilateral is 180° .

$$\angle C + \angle A = 180^\circ$$

$$\angle C = 180^\circ - 100^\circ = 80^\circ$$

(iii) We know that

The sum of both pair of opposite angles of a cyclic quadrilateral is 180° .

$$\angle B + \angle D = 180^\circ$$

$$\angle B = 180^\circ - 80^\circ = 100^\circ$$

OR

i. In a cyclic quadrilateral, all the four vertices of the quadrilateral lie on the circumference of the circle.

ii. The four sides of the inscribed quadrilateral are the four chords of the circle.

iii. The sum of a pair of opposite angles is 180° (supplementary). Let $\angle A$, $\angle B$, $\angle C$, and $\angle D$ be the four angles of an inscribed quadrilateral. Then, $\angle A + \angle C = 180^\circ$ and $\angle B + \angle D = 180^\circ$.

